



Installation Instructions

POINT I/O Module with 8 Configurable 24V DC Points

Catalog Number 1734-8CFG

Topic	Page
Important User Information	2
Environment and Enclosure	3
Prevent Electrostatic Discharge	4
About the Module	5
Before You Begin	5
Install the Mounting Base	7
Install the I/O Module	8
Install the Removable Terminal Block	10
Remove a Mounting Base	11
Wire the Module	13
Wiring Diagram	14
Configure the Module	15
Interpret the Indicators	17
Specifications	19

Important User Information

Solid state equipment has operational characteristics differing from those of electromechanical equipment. Safety Guidelines for the Application, Installation and Maintenance of Solid State Controls (Publication SGI-1.1 available from your local Rockwell Automation sales office or online at <http://literature.rockwellautomation.com>) describes some important differences between solid state equipment and hard-wired electromechanical devices. Because of this difference, and also because of the wide variety of uses for solid state equipment, all persons responsible for applying this equipment must satisfy themselves that each intended application of this equipment is acceptable.





In no event will Rockwell Automation, Inc. be responsible or liable for indirect or consequential damages resulting from the use or application of this equipment.

The examples and diagrams in this manual are included solely for illustrative purposes. Because of the many variables and requirements associated with any particular installation, Rockwell Automation, Inc. cannot assume responsibility or liability for actual use based on the examples and diagrams.

No patent liability is assumed by Rockwell Automation, Inc. with respect to use of information, circuits, equipment, or software described in this manual.

Reproduction of the contents of this manual, in whole or in part, without written permission of Rockwell Automation, Inc., is prohibited.

Throughout this manual, when necessary, we use notes to make you aware of safety considerations.

WARNING 	Identifies information about practices or circumstances that can cause an explosion in a hazardous environment, which may lead to personal injury or death, property damage, or economic loss.
IMPORTANT	Identifies information that is critical for successful application and understanding of the product.
ATTENTION 	Identifies information about practices or circumstances that can lead to personal injury or death, property damage, or economic loss. Attentions help you identify a hazard, avoid a hazard and recognize the consequences.
SHOCK HAZARD 	Labels may be on or inside the equipment (for example, drive or motor) to alert people that dangerous voltage may be present.
BURN HAZARD 	Labels may be on or inside the equipment (for example, drive or motor) to alert people that surfaces may reach dangerous temperatures.

Environment and Enclosure

ATTENTION

This equipment is intended for use in a Pollution Degree 2 industrial environment, in overvoltage Category II applications (as defined in IEC publication 60664-1), at altitudes up to 2000 meters (6562 ft) without derating.

This equipment is considered Group 1, Class A industrial equipment according to IEC/CISPR Publication 11. Without appropriate precautions, there may be potential difficulties ensuring electromagnetic compatibility in other environments due to conducted as well as radiated disturbance.

This equipment is supplied as open-type equipment. It must be mounted within an enclosure that is suitably designed for those specific environmental conditions that will be present and appropriately designed to prevent personal injury resulting from accessibility to live parts. The enclosure must have suitable flame-retardant properties to prevent or minimize the spread of flame, complying with a flame spread rating of 5VA, V2, V1, V0 (or equivalent) if non-metallic. The interior of the enclosure must be accessible only by the use of a tool. Subsequent sections of this publication may contain additional information regarding specific enclosure type ratings that are required to comply with certain product safety certifications.

In addition to this publication, see:

- Industrial Automation Wiring and Grounding Guidelines, Allen-Bradley publication [1770-4.1](#), for additional installation requirements.
 - NEMA Standards publication 250 and IEC publication 60529, as applicable, for explanations of the degrees of protection provided by different types of enclosure
-

Prevent Electrostatic Discharge

ATTENTION

This equipment is sensitive to electrostatic discharge, which can cause internal damage and affect normal operation. Follow these guidelines when you handle this equipment.

- Touch a grounded object to discharge potential static.
 - Wear an approved grounding wriststrap.
 - Do not touch connectors or pins on component boards.
 - Do not touch circuit components inside the equipment.
 - Use a static-safe workstation, if available.
 - Store the equipment in appropriate static-safe packaging when not in use.
-

ATTENTION

POINT I/O is grounded through the DIN rail to chassis ground. Use zinc plated, yellow-chromate steel DIN rail to be sure of proper grounding. The use of other DIN rail materials, such as aluminum and plastic that can corrode, oxidize, or are poor conductors, can result in improper or intermittent grounding. Secure DIN rail to mounting surface approximately every 200 mm (7.87 in.) and use end-anchors appropriately.

ATTENTION

To comply with the CE Low Voltage Directive (LVD), all connected I/O must be powered from a source compliant with the following:
Safety Extra Low Voltage (SELV) or Protected Extra Low Voltage (PELV).

About the Module

The 1734-8CFG module is a 24V DC I/O module with 8 self-configuring points. Each of the I/O points can be a DC input or output. The module supports removal and insertion under power, auto-address, and auto-baud in compliance with the POINTBus backplane.

Before You Begin

See the figures to familiarize yourself with major parts of the module, noting that the wiring base assembly is one of the following:

- 1734-TB or 1734-TBS POINT I/O two-piece terminal base, which includes the 1734-RTB removable terminal block and 1734-MB mounting base
- 1734-TOP or 1734-TOPS POINT I/O one-piece terminal base

The 1734-8CFG module is not compatible with 1734-TB3, 1734-TB3S, 1734-TOP3, and 1734-TOP3S terminal bases.

6 POINT I/O Module with 8 Configurable 24V DC Points

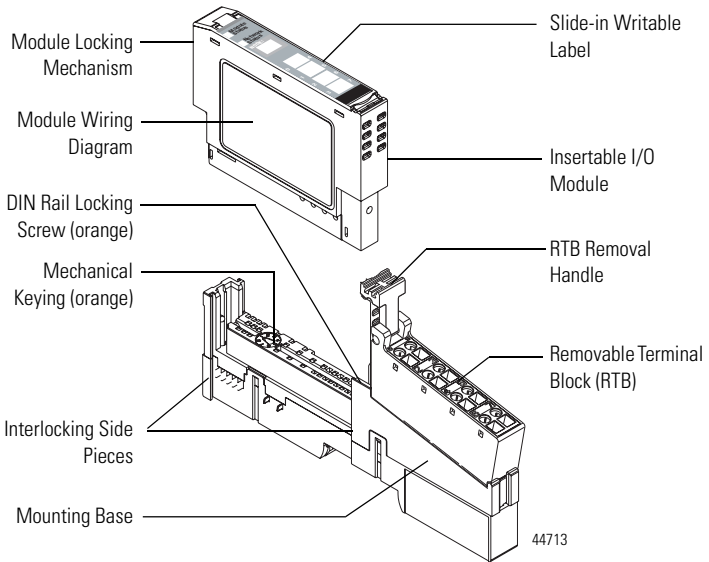

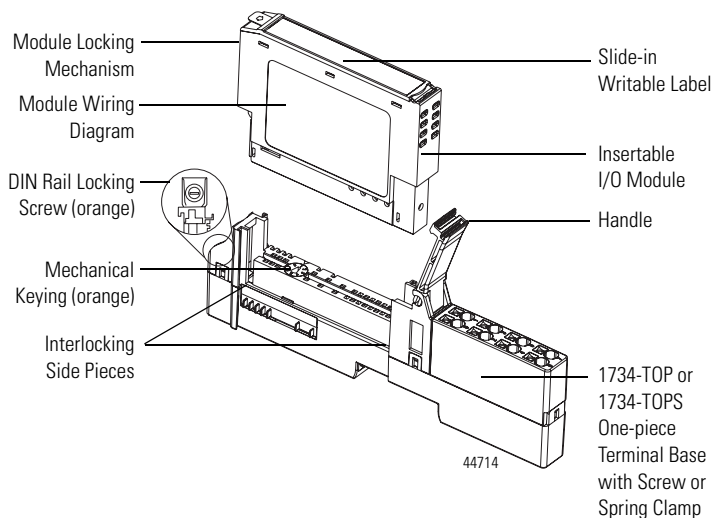

Install the Mounting Base

Follow these steps to install the mounting base on the DIN rail.

1. Position the mounting base vertically above the installed units, for example, adapter, power supply, or existing module.
2. Slide the mounting base down so that the interlocking side pieces engage the adjacent module or adapter.
3. Press firmly to seat the mounting base on the DIN rail until the mounting base snaps into place.
4. To remove the mounting base from the DIN rail, remove the module, and use a small bladed screwdriver to rotate the base locking screw to a vertical position. This releases the locking mechanism. Then lift straight up to remove.

Install the I/O Module

The module can be installed before, or after base installation. Make sure the mounting base is correctly keyed before installing the module into the mounting base. In addition, make sure the mounting base locking screw is positioned horizontal referenced to the base.

1734-TB Base

Turn the keyswitch to align the number with the notch. Notch position 1 is shown.

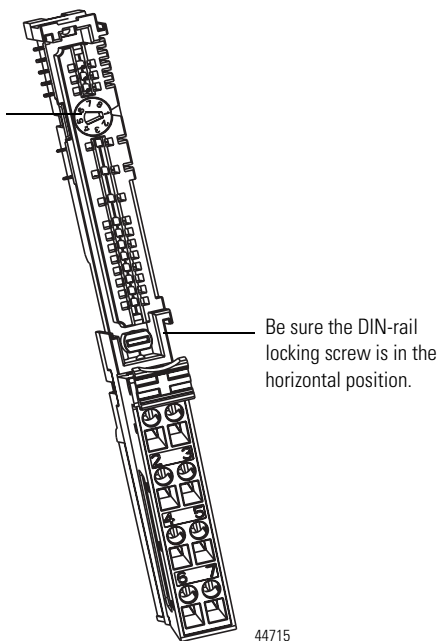
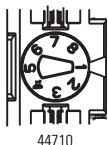

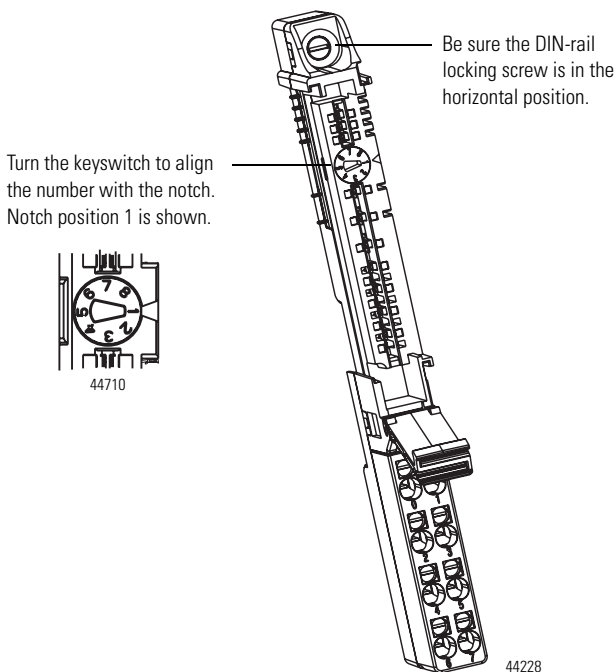
1734-TOP Base

Follow these steps to install the module.

1. Use a bladed screwdriver to rotate the keyswitch on the mounting base clockwise until the number required for the type of module being installed aligns with the notch in the base.
2. Make certain the DIN-rail locking screw is in the horizontal position. (You cannot insert the module if the locking mechanism is unlocked.)
3. Insert the module straight down into the mounting base and press to secure. The module will lock into place.

Install the Removable Terminal Block

Read this for information if a removable terminal block (RTB) is supplied with your wiring base assembly, noting that 1734-TOP and 1734-TOPS bases do not have an RTB.

To insert the RTB, proceed as follows. Note that if you pull up on the RTB handle to remove the RTB, you can remove and replace the mounting base as necessary without removing any of the wiring.

1. Insert the end opposite the handle into the base unit, noting that this end has a curved section that engages with the wiring base.
2. Rotate the terminal block into the wiring base until it locks itself into place.
3. If an I/O module is installed, snap the RTB handle into place on the module.

Remove a Mounting Base

To remove a mounting base, you must first remove any installed module and the module installed in the base to the right.

1. For a module with a two-piece terminal base, use these steps; otherwise, use [step 2](#).
 - a. Remove the removable terminal block (RTB), if wired.
 - b. Unlatch the RTB handle on the I/O module.
 - c. Pull on the RTB handle to remove the RTB.
2. Press on the module lock on the top of the module.
3. Pull on the I/O module to remove from the base.
4. Repeat steps 1, 2, 3, and 4 for the module to the right.
5. Lift straight up to remove.

Install a 1734-TOPS Base

1. Position the base vertically above the installed units, such as an adapter, power supply, or existing module.
2. Slide the base down, allowing the interlocking side pieces to engage the adjacent installed unit.
3. Press firmly to seat the base on the DIN rail until the base snaps into place.
4. Verify that the DIN-rail locking screw is in a horizontal, locked position before inserting an I/O module.

Remove a 1734-TOPS Base

To remove a wiring base from the DIN rail, you must remove the module installed to the right of the base.

1. Squeeze the module locking mechanism of the module to the right of the base, pulling up to remove the module.
2. Turn the orange locking screw to a vertical position to unlock the base from the DIN rail.
3. Slide the base up to release it from its mating units.

Wire the Module

See the figures and tables for information about how to wire the module.

1734-8CFG

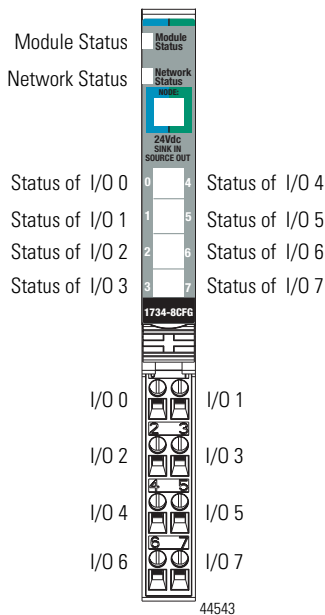

Note that voltage and current to the module is applied through the adapter, the 1734-FPD module, or the 1734-EP24DC module. $V = 10 \dots 28.8$ V DC.

14 POINT I/O Module with 8 Configurable 24V DC Points

Wiring Diagram

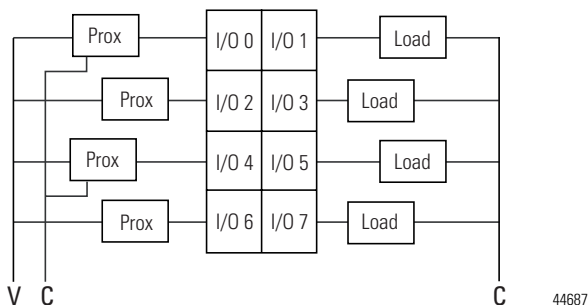

If a connection to Common or the Supply Voltage is required for two- or three-wire devices, then a 1734-CTM or 1734-VTM can be used.

Each I/O point is either Input or Output.

Channel	Terminal Number		
	I/O	Common	Voltage
0	0	External ⁽¹⁾	External ⁽²⁾
1	1		
2	2		
3	3		
4	4		
5	5		
6	6		
7	7		

10/28.8 V DC is supplied through the internal power bus.

⁽¹⁾ Common connections require an external connection, such as a 1734-CTM module.

⁽²⁾ Supply Voltage Connections require an external connection such as a 1734-VTM module.

Configure the Module

Read this section for information about how to communicate with your module.

I/O messages are sent to (consumed) and received from (produced) the POINT I/O modules. These messages are mapped into the processor's or scanner's memory. Each module produces 1 byte of input data and consumes 1 byte of I/O data (scanner Tx).

Default Data Map - Produced Assembly Instance 4

Message Size: 1 Byte

	7	6	5	4	3	2	1	0
Data	Pt 07	Pt 06	Pt 05	Pt 04	Pt 03	Pt 02	Pt 01	Pt 00

Where: Pt = state of the input point

In RSLogix5000, the default tag will be AdapterName:SlotNumber:I.Data.
The data type is a SINT.

Default Data Map - Consumed Assembly Instance 34

Message Size: 1 Byte

	7	6	5	4	3	2	1	0
Data	Pt 07	Pt 06	Pt 05	Pt 04	Pt 03	Pt 02	Pt 01	Pt 00

Where: Pt = state of the output point

In RSLogix5000, the default tag will be AdapterName:SlotNumber:O.Data.
The data type is a SINT.

Default Data Map - Configuration Assembly Instance 103**Message Size: 8 Bytes**

	7	6	5	4	3	2	1	0
Data [0]	Group Off2On Input filter							
Data [1]								
Data [2]	Group On2Off Input filter							
Data [3]								
Data [4]	FltM 7	FltM 6	FltM 5	FltM 4	FltM 3	FltM 2	FltM 1	FltM 0
Data [5]	FltV 7	FltV 6	FltV 5	FltV 4	FltV 3	FltV 2	FltV 1	FltV 0
Data [6]	IdIM 7	IdIM 6	IdIM 5	IdIM 4	IdIM 3	IdIM 2	IdIM 1	IdIM 0
Data [7]	IdIV 7	IdIV 6	IdIV 5	IdIV 4	IdIV 3	IdIV 2	IdIV 1	IdIV 0

Where:

Filter = 0 to 65000 ms (0 = default)

Filter = 0 to 65535 ms (1000 = default)

FltM = Fault Mode (0 = Fault Value (default), 1 = Hold Last State)

FltV = Fault Value (0 = OFF (default), 1 = ON)

IdIM = Idle Mode (0 = Idle Value (default), 1 = Hold Last State)

IdIV = Idle Value (0 = OFF (default), 1 = ON)

In RSLogix5000, the default tags will be:

- AdapterName:SlotNumber:C.FilterOffOn
- AdapterName:SlotNumber:C.FilterOnOff
- AdapterName:SlotNumber:C.PtPointNumberFaultMode
- AdapterName:SlotNumber:C.PtPointNumberFaultValue
- AdapterName:SlotNumber:C.PtPointNumberProgMode
- AdapterName:SlotNumber:C.PtPointNumberProgValue

Interpret the Indicators

See the figure and table that show how to interpret indicators.

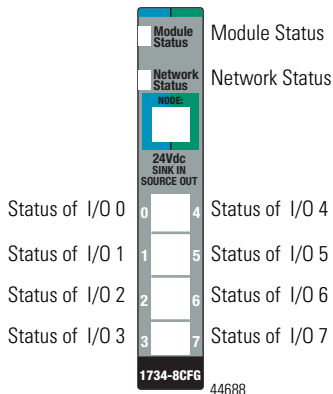

Indicator	State	Description
Module status	Off	No power applied to device.
	Green	Device operating normally.
	Flashing green	Device needs commissioning due to configuration missing, incomplete or incorrect.
	Flashing red	Recoverable fault.
	Red	Unrecoverable fault may require device replacement.
	Flashing red/green	Device is in self-test.

18 POINT I/O Module with 8 Configurable 24V DC Points

Indicator	State	Description
Network status	Off	Device is not online. - Device has not completed dup_MAC_id test. - Device not powered - check module status indicator.
	Flashing green	Device is online but has no connections in the established state.
	Green	Device is online and has connections in the established state.
	Flashing red	One or more I/O connections in timed-out state.
	Red	Critical link failure - failed communication device. Device detected error that prevents it communicating on the network.
	Flashing red/green	Communication faulted device - the device has detected a network access error and is in communication faulted state. Device has received and accepted an Identify Communication Faulted Request - long protocol message.
I/O status	Off	Input is in the OFF state. Output is in the OFF state.
	Yellow	Input is in the ON state. Output is in the ON state.

Specifications

Specifications for POINT I/O Module 1734-8CFG DC Input

Attribute	Value
On-state voltage, min	11V DC
On-state current, min	2.0 mA
On-state current, max	5.0 mA
Off-state voltage, max	5V DC
Off-state current, min	1.5 mA
Input filter	Each input independently settable in 1 ms intervals (truncated to 1 ms resolution). Default value is 1000 ms.
Off to On filter, min	0 ms
Off to On filter, max	65535 ms
On to Off filter, min	0 ms
On to Off filter, max	65535 ms

Specifications for POINT I/O Module 1734-8CFG DC Output

Attribute	Value
On-state voltage range, min	10V DC
On-state voltage range, max	28.8V DC
On-state voltage range, nom	24V DC
On-state voltage drop, max	0.4V DC
On-state current, max	0.5 A
Off-state leakage, max	0.5 mA
Module current (all outputs), max	3.0 A
Surge current - for 100 ms, repeatable every 2 s, max	1.0 A

General Specifications

Attribute	Value
Module location	1734-TB, 1734-TBS, 1734-TOP, and 1734-TOPS bases
POINTBus current, max	100 mA @ 5V DC
Power dissipation, max	2.6 W @ 28.8V DC
Thermal dissipation, max	8.9 BTU/hr @ 28.8V DC
Isolation voltage	50V (continuous), Reinforced Insulation Type Type tested at 2121V DC for 60 s, field-side to system No isolation between individual channels
Field power bus Supply voltage, nom Voltage range	24V DC 10...28.8V DC
Dimensions HxWxL, approx.	56 x 12 x 75.5 mm 2.2 x 0.47 x 2.97 in.
Terminal block screw torque	Determined by installed terminal block
Keyswitch position	1
Reverse polarity protection	Yes
Enclosure type rating	None (open-style)
Wire size	Determined by installed terminal block.
Wire category	1 - on signal ports ⁽¹⁾
Pilot duty rating	Not rated

⁽¹⁾ Use this Conductor Category information for planning conductor routing. Refer to Industrial Automation Wiring and Grounding Guidelines, publication [1770-4.1](#).

Environmental Specifications

Attribute	Value
Temperature, operating	IEC 60068-2-1 (Test Ad, Operating Cold), IEC 60068-2-2 (Test Bd, Operating Dry Heat), IEC 60068-2-14 (Test Nb, Operating Thermal Shock): -20...55 °C (-4...131 °F)
Temperature, non-operating	IEC 60068-2-1 (Test Ab, Unpackaged Non-operating Cold), IEC 60068-2-2 (Test Bb, Unpackaged Non-operating Dry Heat), IEC 60068-2-14 (Test Na, Unpackaged Non-operating Thermal Shock): -40...85°C (-40...185°F)
Relative humidity	IEC 60068-2-30 (Test Db, Unpackaged Damp Heat): 5...95% noncondensing
Vibration	IEC 60068-2-6 (Test Fc, Operating): 5g @ 10...500 Hz
Shock, operating	IEC 60068-2-27 (Test Ea, Unpackaged Shock) 30 g
Shock, non-operating	IEC 60068-2-27 (Test Ea, Unpackaged Shock) 50 g
Emissions	CISPR 11: Group 1, Class A
ESD immunity	IEC 61000-4-2: 6 kV contact discharges 8 kV air discharges
Radiated RF immunity	IEC 61000-4-3: 10V/m with 1 kHz sine-wave 80% AM from 80...2000 MHz 10V/m with 200 Hz 50% Pulse 100% AM at 900 MHz 10V/m with 200 Hz 50% Pulse 100% AM at 1890 MHz 3V/m with 1 kHz sine-wave 80% AM from 2000...2700 MHz

22 POINT I/O Module with 8 Configurable 24V DC Points

Environmental Specifications (Continued)

Attribute	Value
EFT/B immunity	IEC 61000-4-4: ±3 kV at 5 kHz on signal ports
Surge transient immunity	IEC 61000-4-5: ±1 kV line-line (DM) and ±2 kV line-earth (CM) on signal ports
Conducted RF immunity	IEC 61000-4-6: 10V rms with 1 kHz sine-wave 80% AM from 150 kHz...80 MHz

Certifications

Certification (when product is marked)⁽¹⁾	Value
CE	European Union 2004/108/EC EMC Directive, compliant with: EN 61326-1; Meas./Control/Lab., Industrial Requirements EN 61000-6-2; Industrial Immunity EN 61000-6-4; Industrial Emissions EN 61131-2; Programmable Controllers (Clause 8, Zone A & B)
C-Tick	Australian Radiocommunications Act, compliant with: AS/NZS CISPR 11; Industrial Emissions

⁽¹⁾ See the Product Certification link at <http://www.ab.com> for Declarations of Conformity, Certificates, and other certification details.

Rockwell Automation Support

Rockwell Automation provides technical information on the Web to assist you in using its products. At <http://support.rockwellautomation.com>, you can find technical manuals, a knowledge base of FAQs, technical and application notes, sample code and links to software service packs, and a MySupport feature that you can customize to make the best use of these tools.

For an additional level of technical phone support for installation, configuration, and troubleshooting, we offer TechConnect support programs. For more information, contact your local distributor or Rockwell Automation representative, or visit <http://support.rockwellautomation.com>.

Installation Assistance

If you experience a problem within the first 24 hours of installation, please review the information that's contained in this manual. You can also contact a special Customer Support number for initial help in getting your product up and running.

United States	1.440.646.3434 Monday – Friday, 8 a.m. – 5 p.m. EST
Outside United States	Please contact your local Rockwell Automation representative for any technical support issues.

New Product Satisfaction Return

Rockwell Automation tests all of its products to ensure that they are fully operational when shipped from the manufacturing facility. However, if your product is not functioning and needs to be returned, follow these procedures.

United States	Contact your distributor. You must provide a Customer Support case number (see phone number above to obtain one) to your distributor in order to complete the return process.
Outside United States	Please contact your local Rockwell Automation representative for the return procedure.

Allen-Bradley, POINT I/O, POINTBus, Rockwell Automation, and TechConnect are trademarks of Rockwell Automation, Inc.

Trademarks not belonging to Rockwell Automation are property of their respective companies.

www.rockwellautomation.com

Power, Control and Information Solutions Headquarters

Americas: Rockwell Automation, 1201 South Second Street, Milwaukee, WI 53204-2496 USA, Tel: (1) 414.382.2000, Fax: (1) 414.382.4444
Europe/Middle East/Africa: Rockwell Automation, Vorstlaan/Boulevard du Souverain 36, 1170 Brussels, Belgium, Tel: (32) 2 663 0600, Fax: (32) 2 663 0640
Asia Pacific: Rockwell Automation, Level 14, Core F, Cyberport 3, 100 Cyberport Road, Hong Kong, Tel: (852) 2887 4788, Fax: (852) 2508 1846